

1. TRACK ASSEMBLY

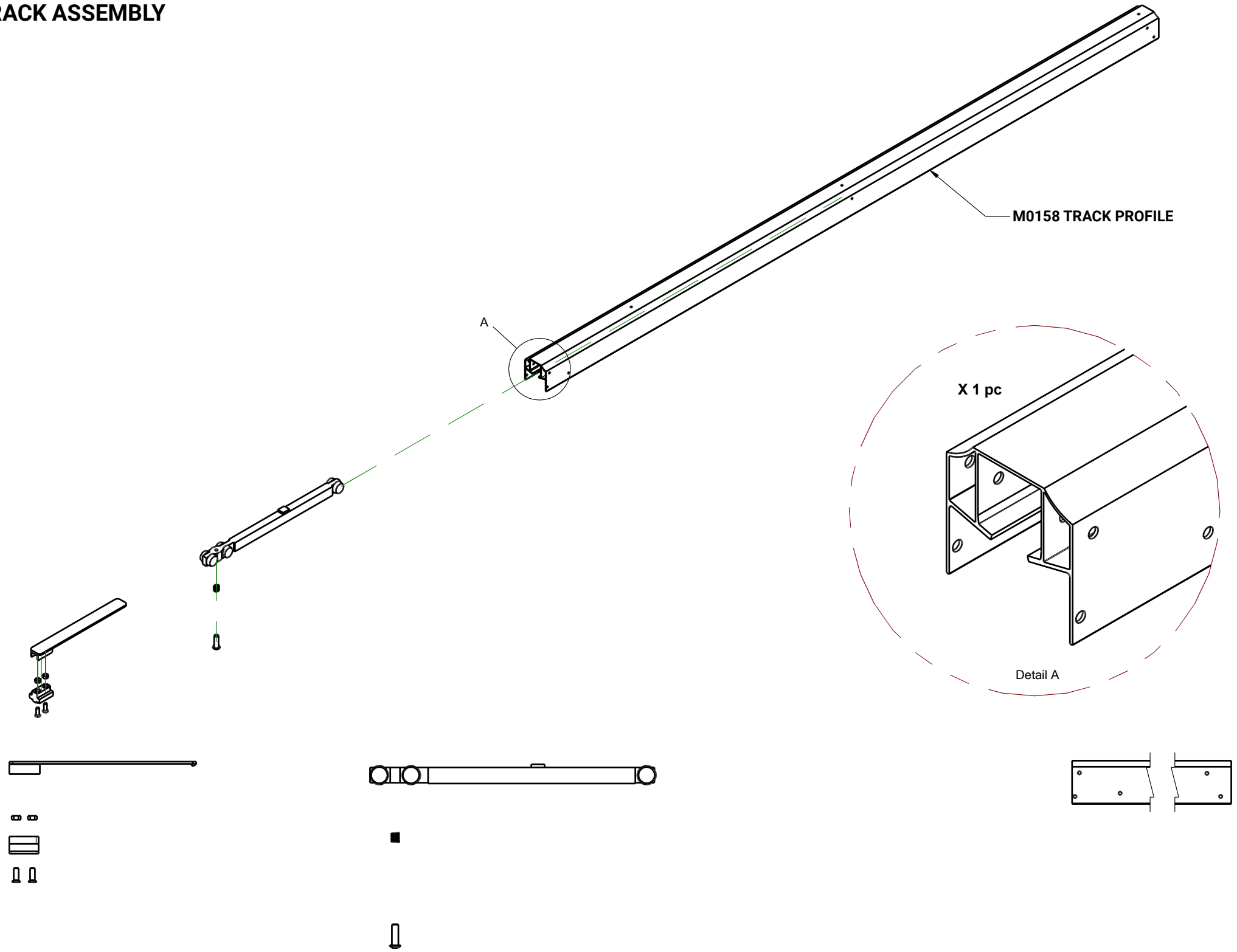

2. TRACK & RECEPTIONS

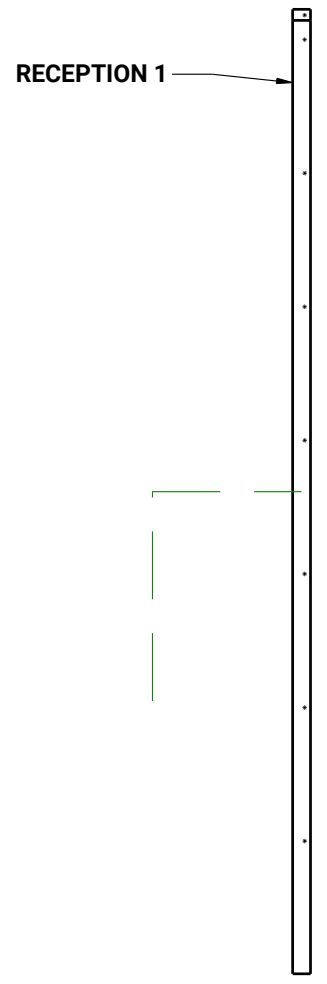
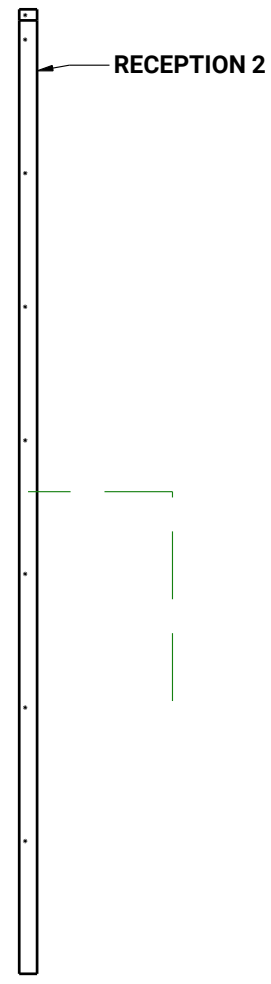
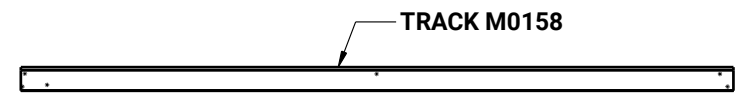
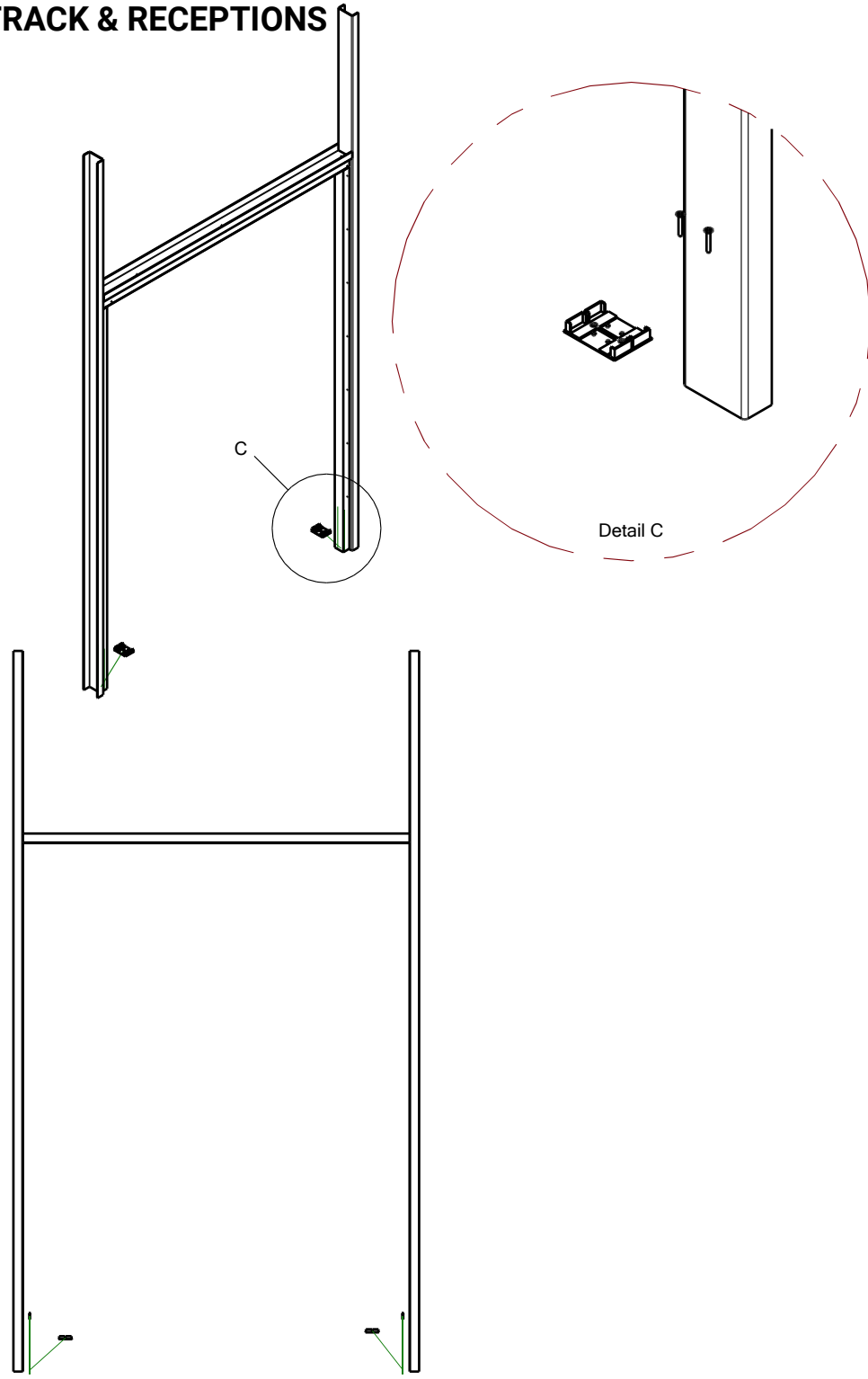

3. FIXING OF M0169 PROFILES

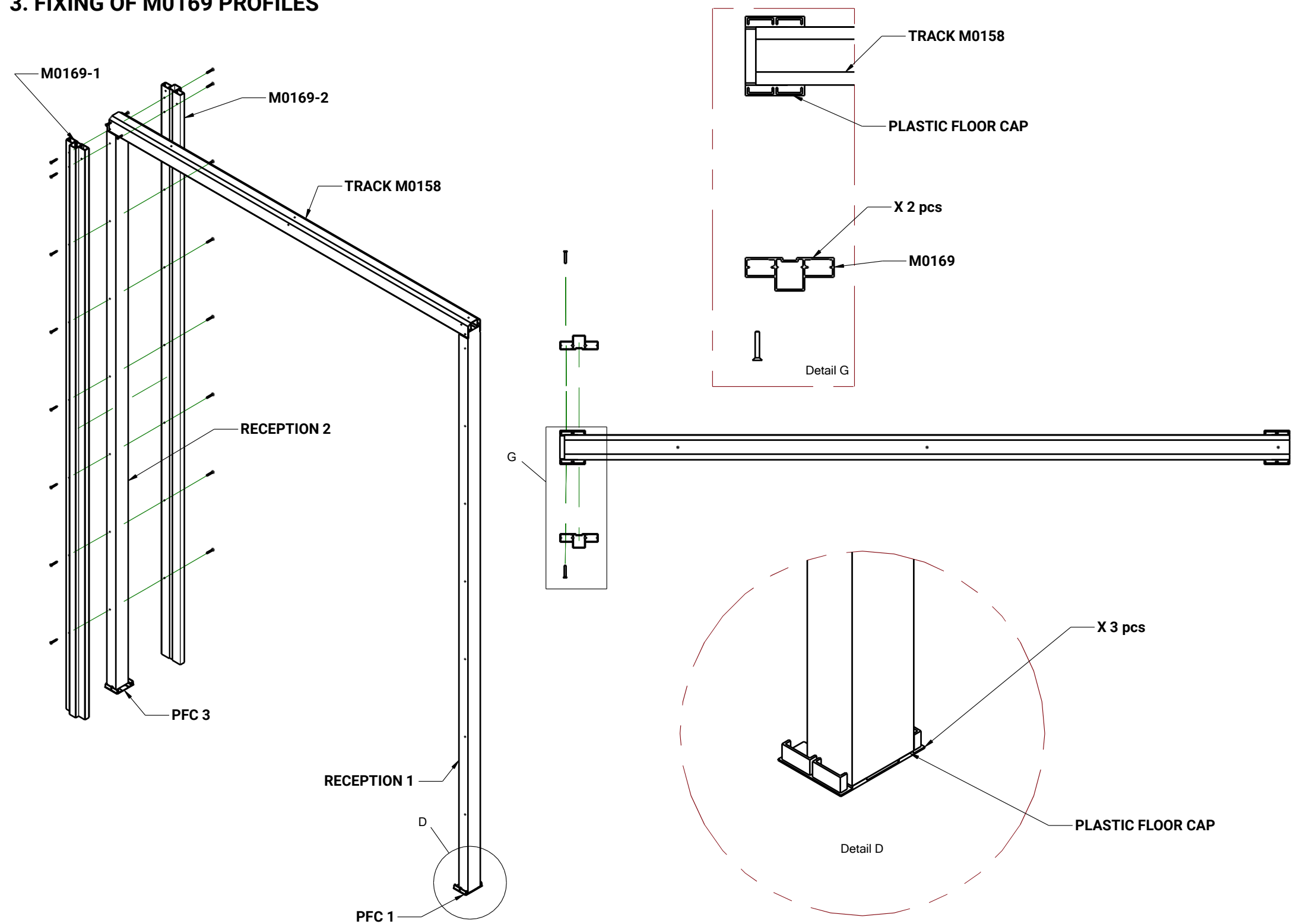

4. ASSEMBLY OF M0171

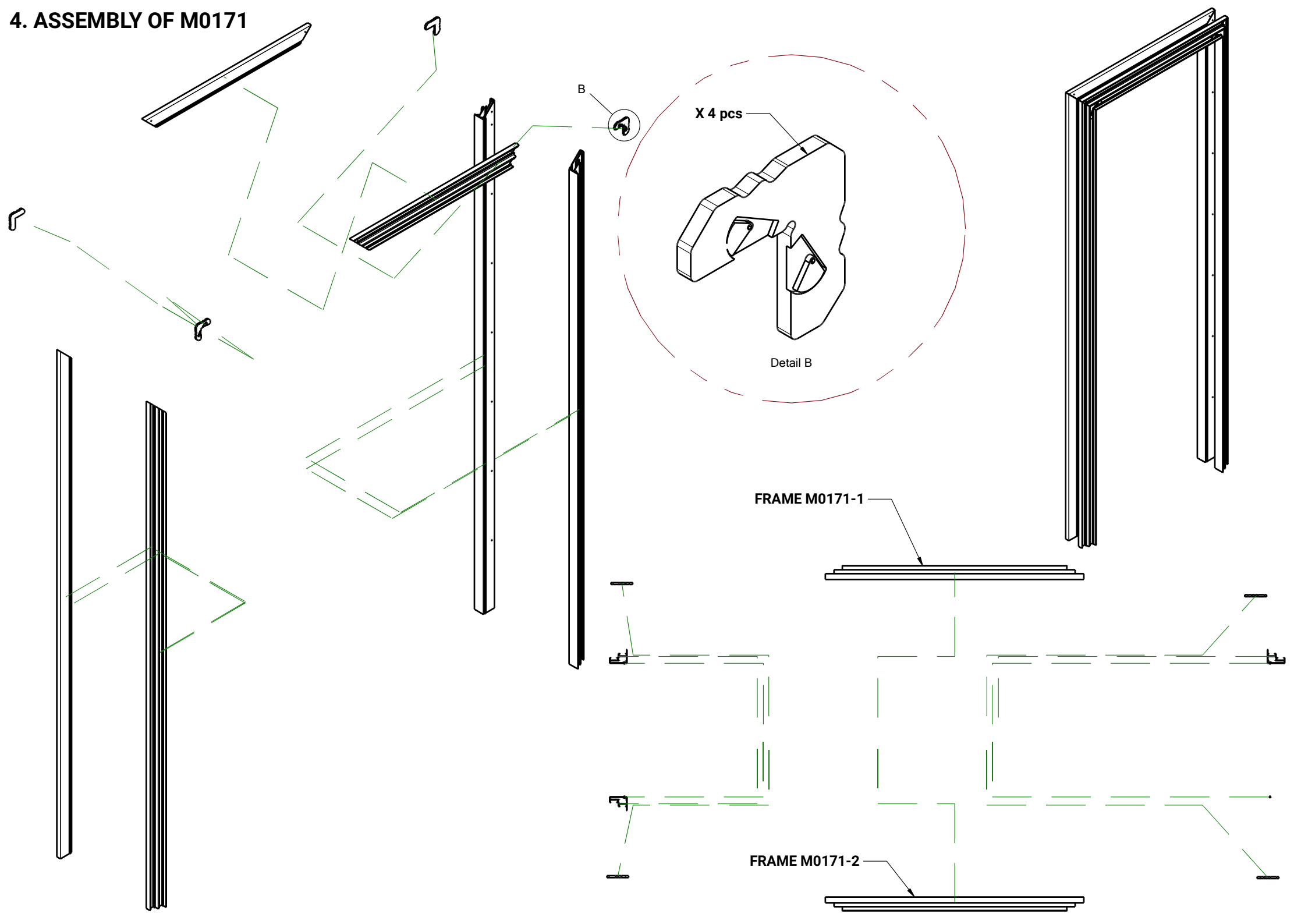

5. MOUNTING OF THE TRACK & RECEPTIONS

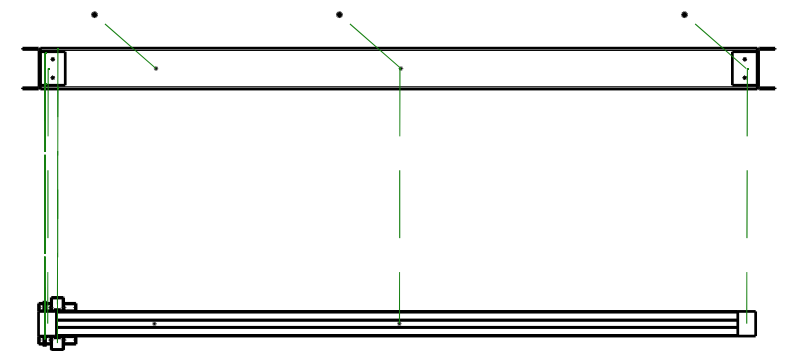
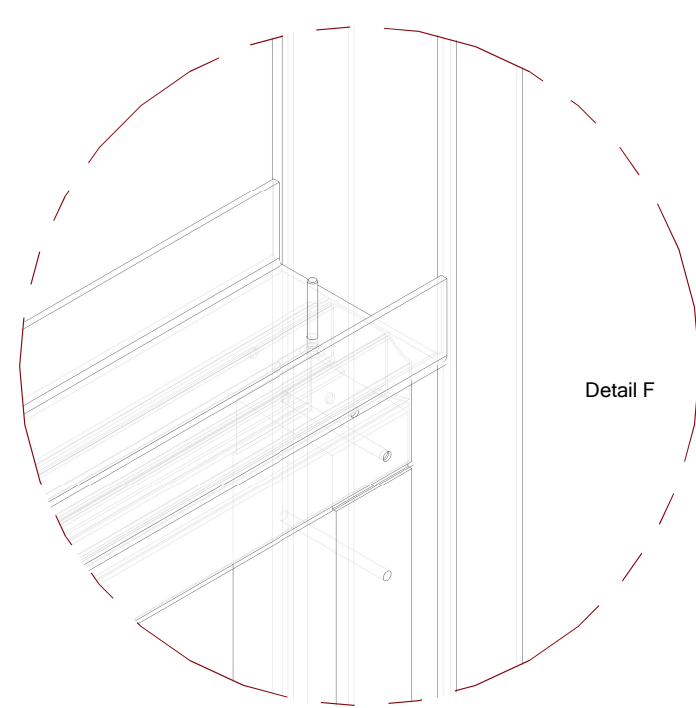
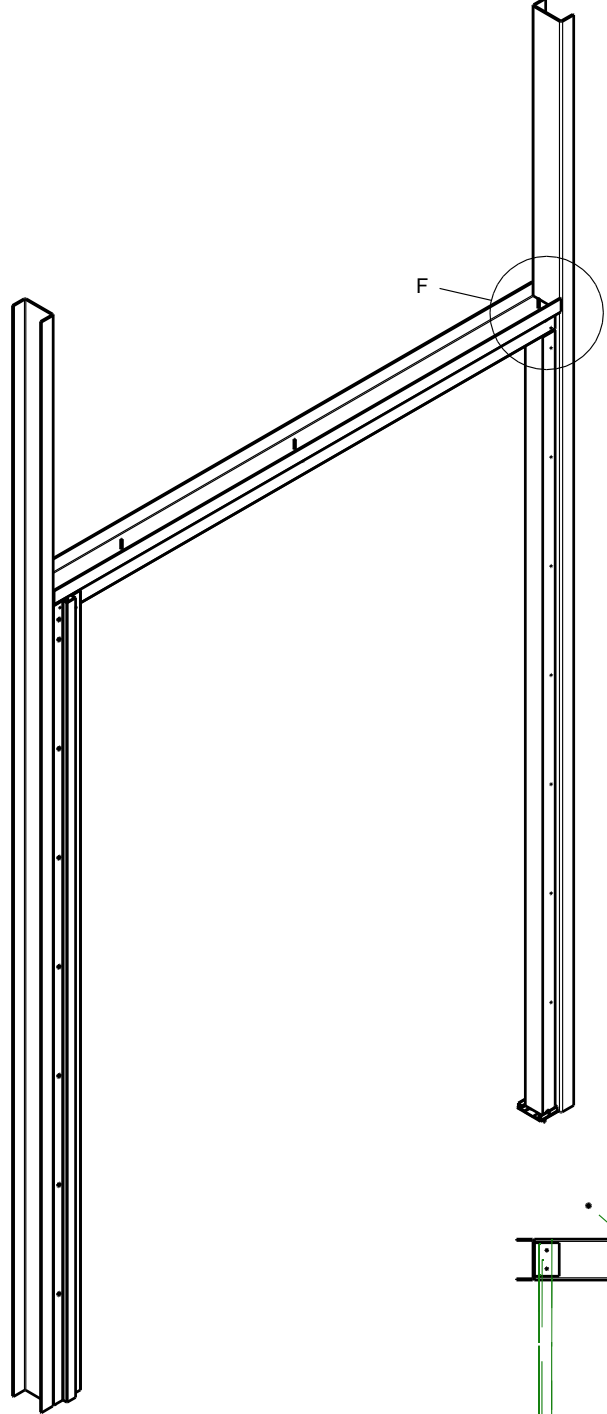
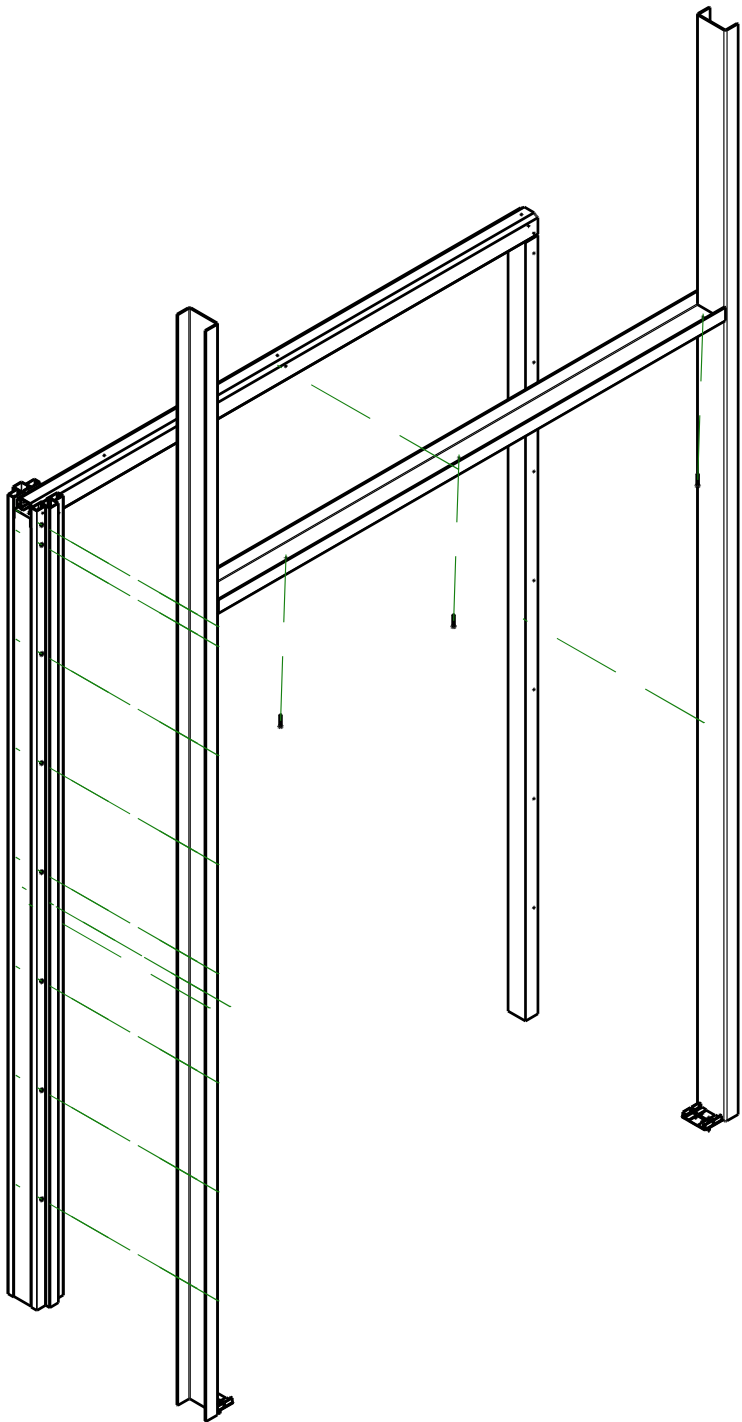

6. MOUNTING OF THE FRAME M0171-1

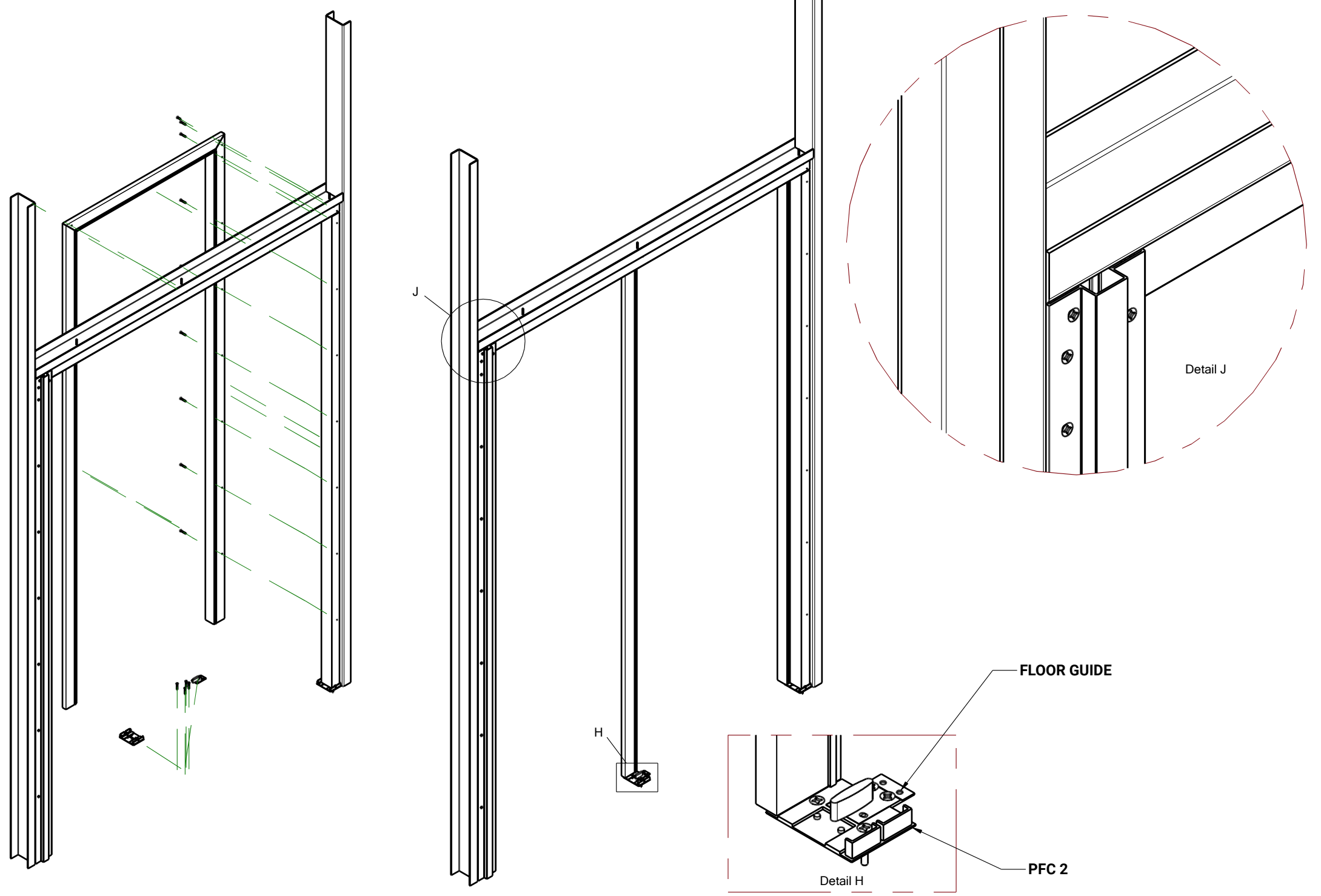

7. FIXING THE SLIDEING MECHANISM ON THE DOORLEAF

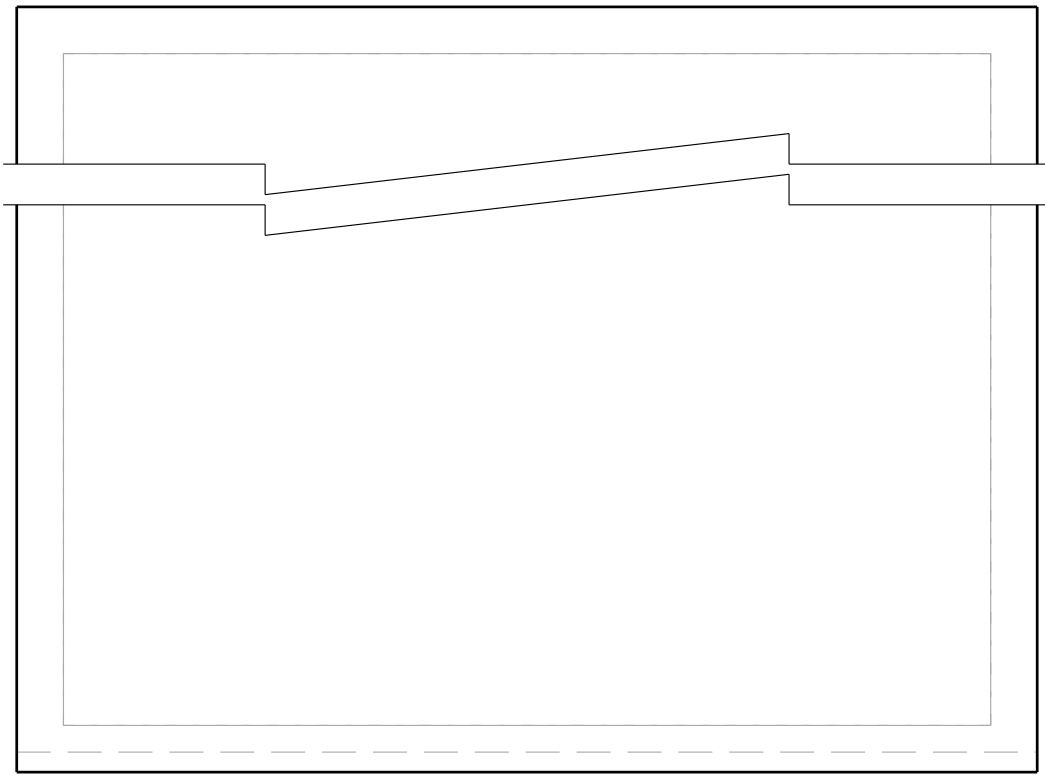
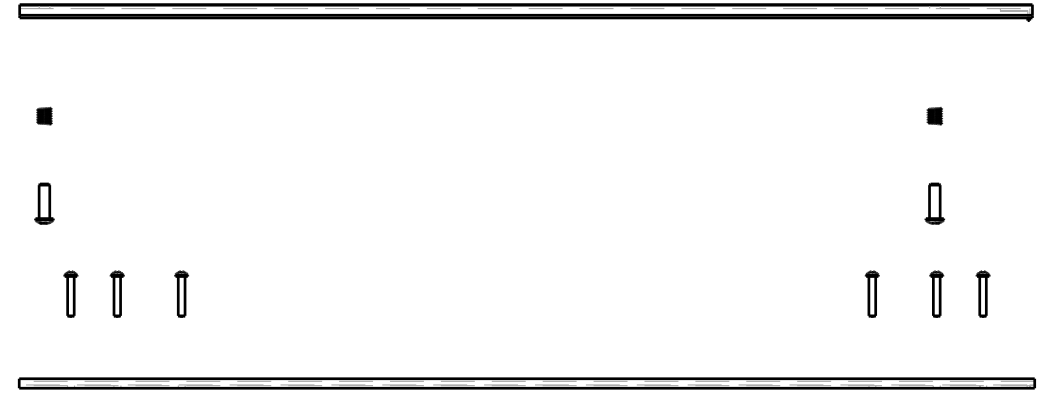
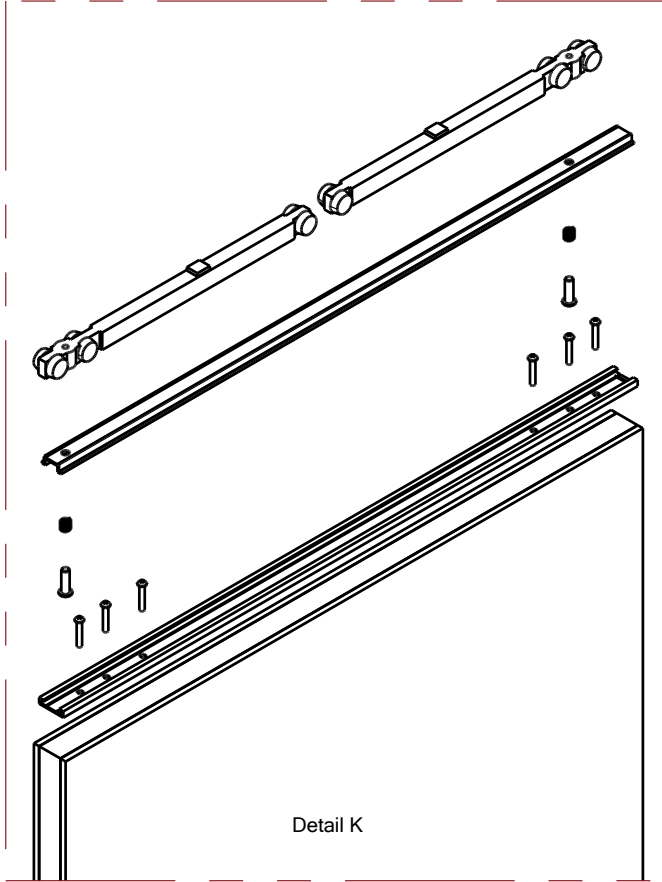
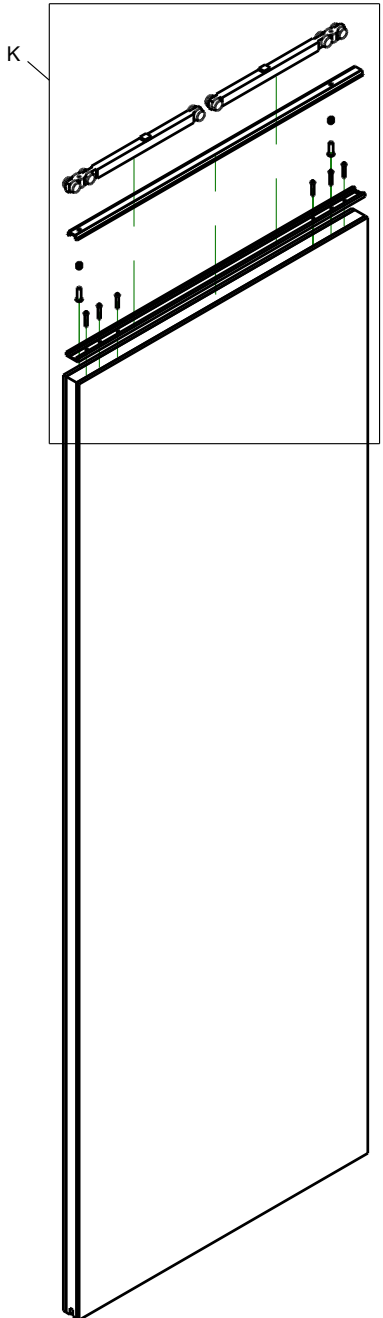

8. HANGING THE DOORLEAF

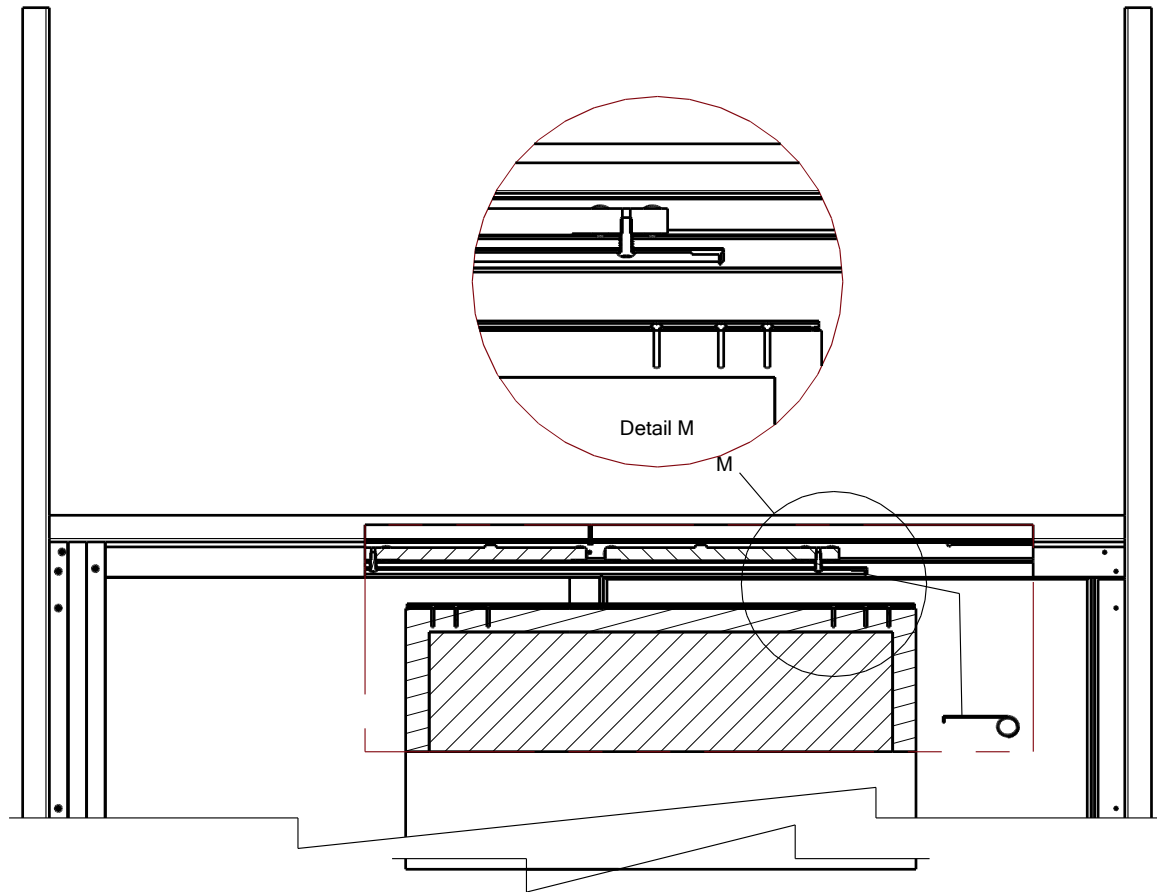
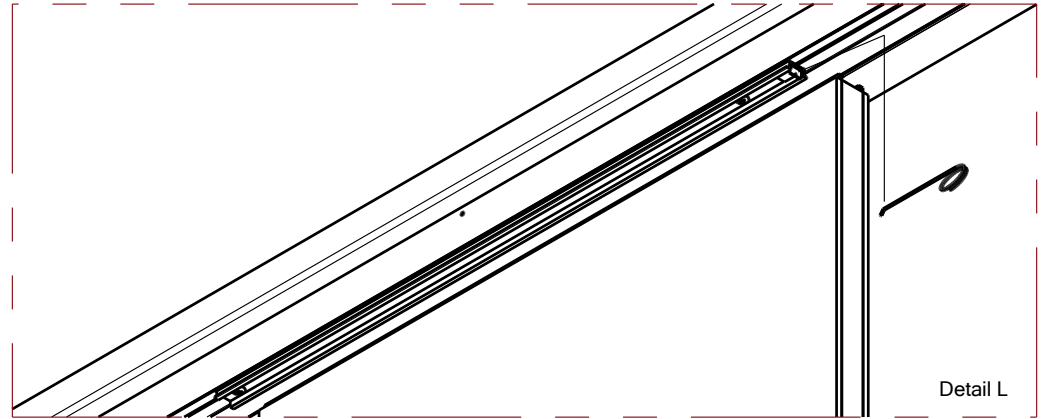
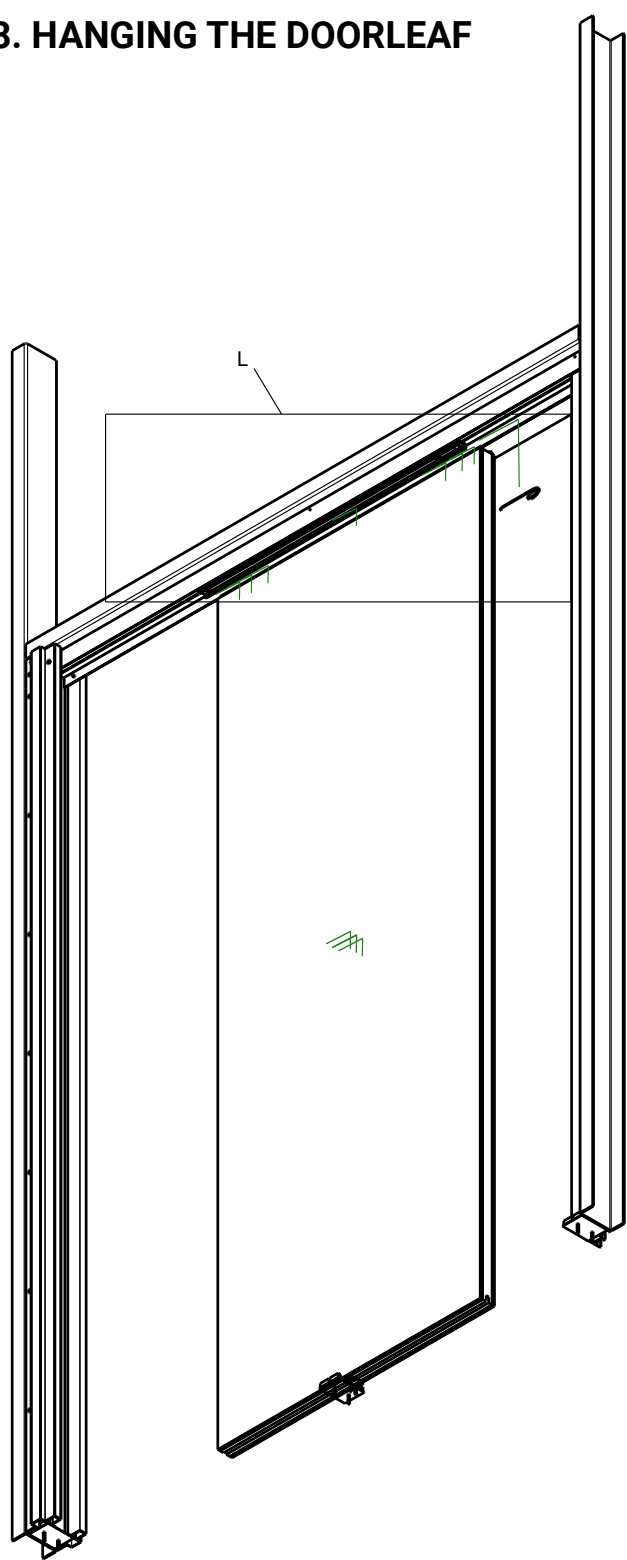

9. MOUNTING OF THE FRAME M0171-2

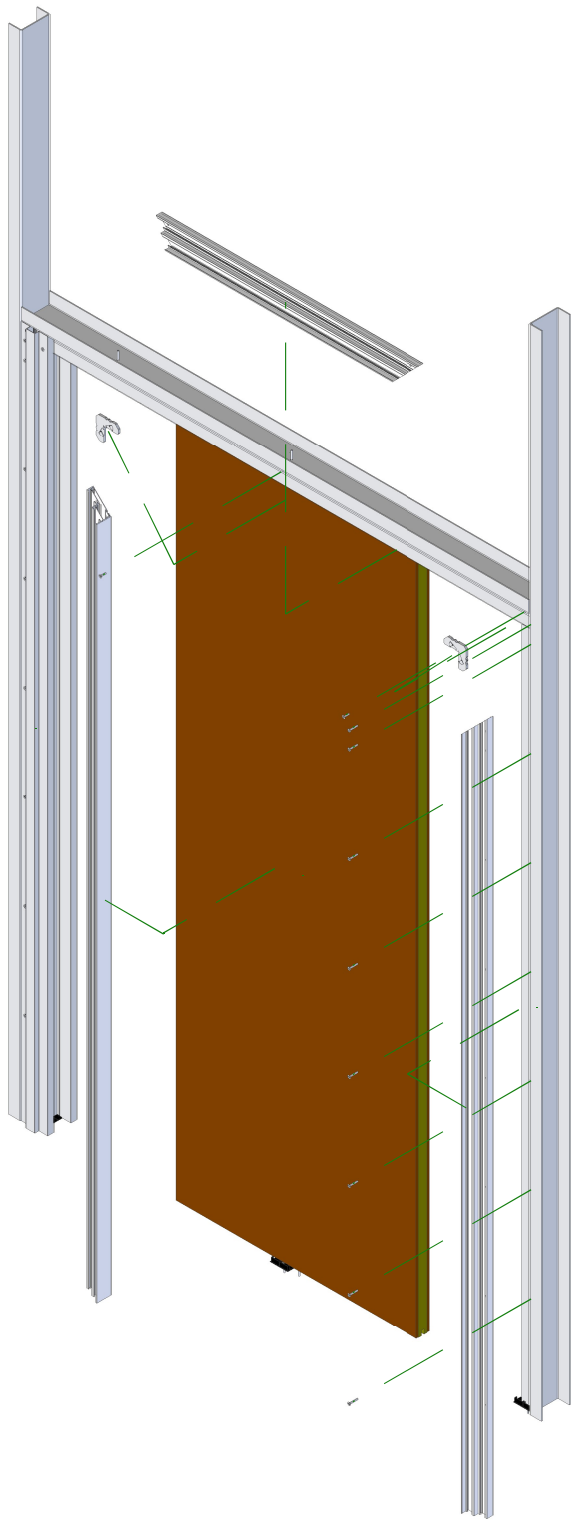

10. FIXING THE GYPSUMBOARDS FROM THE INTERIOR SIDE

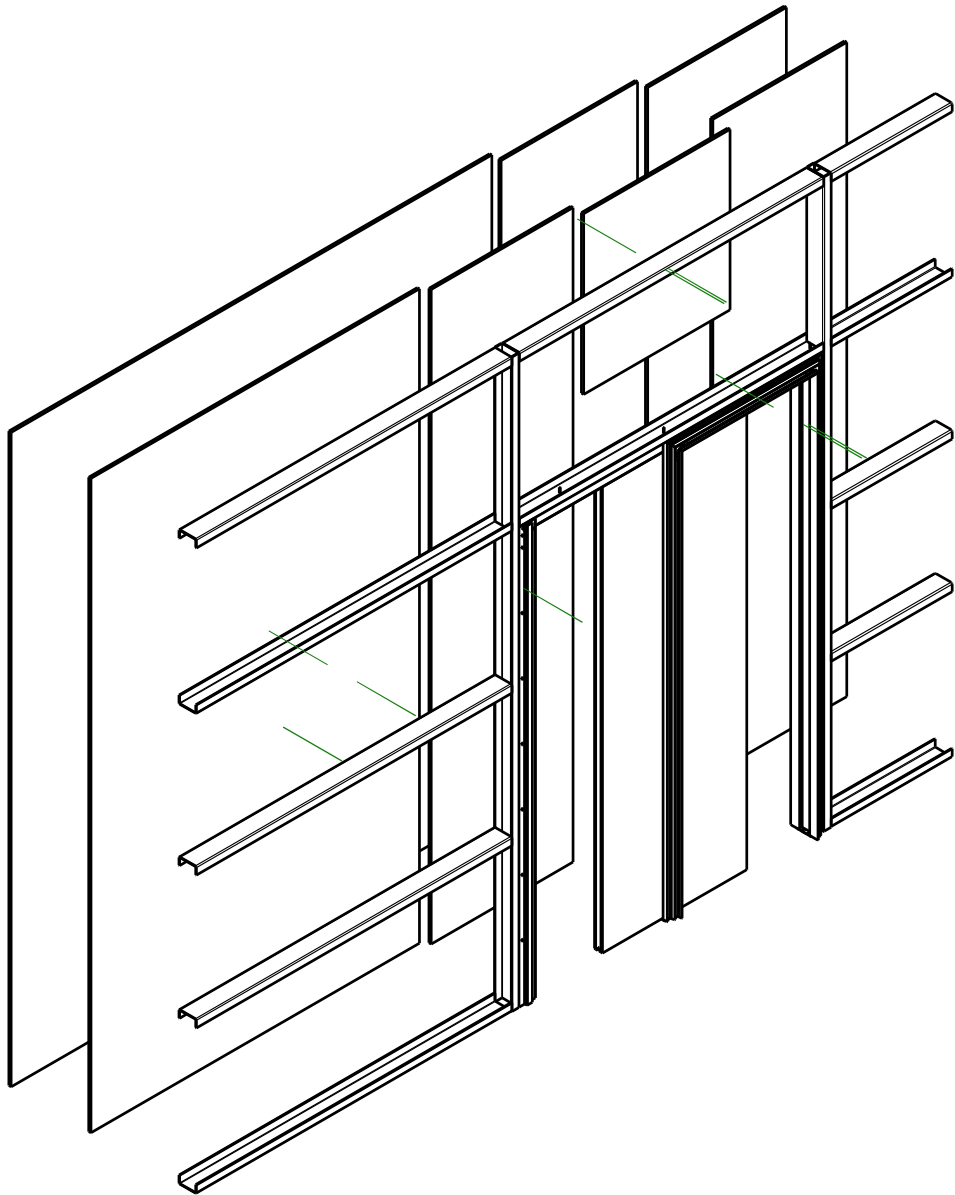

11. FIXING THE GYPSUMBOARDS FROM THE EXTERIOR SIDE

